

醫用工具及配件系列(耳鼻、內窺鏡、關節鏡刨刀) (常規常備齒型)

Medical tools and parts series (Otorhinolaryngologic, endoscopic, arthroscopic shaver blades)

(Conventional and Stock Tooth Profiles)

醫療器具及び部品シリーズ(耳鼻、內視鏡、關節鏡刨刀) (通常常備齒型)

(超鋒利刃口&超防銹 (AA)&超耐磨&超精密密度內外配合)

(Ultra-sharp cutting edge & ultra-high anti-rust (AA) & ultra-high wear-resistant & ultra-high precision cooperation of inner tubes and outer tubes)

(超銳利刃先&超防銹 (AA)&超耐磨&超精度內外接合)

材料: 高硬度高抗衝擊高韌性超級鏡面不銹鋼ASTMF899(HRC54° ~64° 系列等級)

Material: super mirror stainless steel ASTMF899 with high hardness, high impact and high toughness (HRC54° ~64° series)

材質: 高硬度高耐衝擊高韌性スーパー仕上げステンレスASTMF899(HRC54° ~64° シリーズレベル)

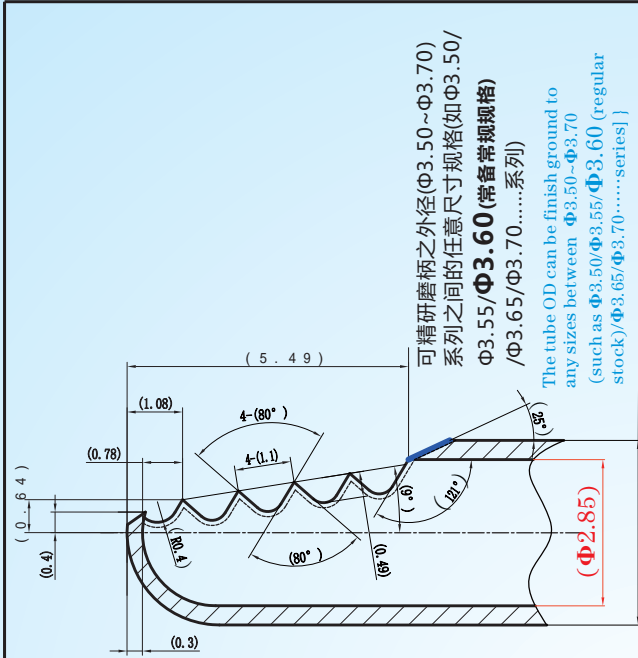

外 (outer)

A

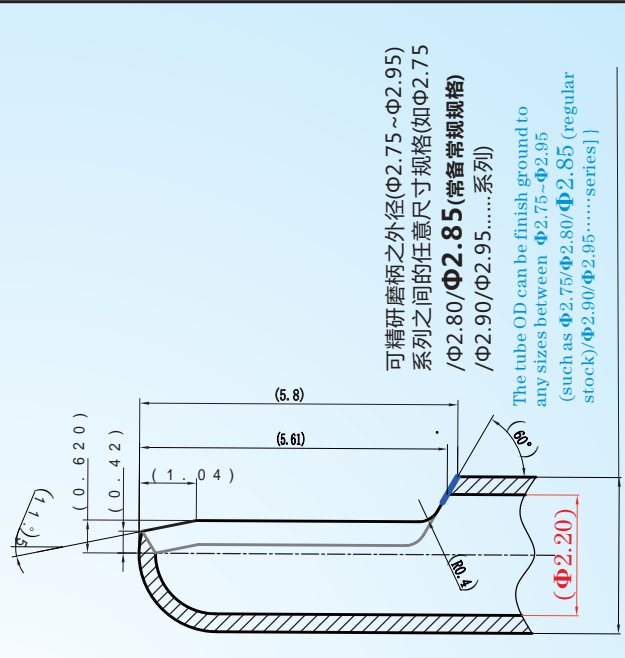

内 (inner)

B

超鋒利刃、超精密密度內外配合、超防銹，超硬度、耐磨，超抗衝擊性能、超韌性，超強度之焊接。
Welding with super sharp edge, ultra-high precision internal and external matching, superhigh rust resistance, superhigh hardness, wear resistance, high impact resistance, superhigh toughness and superhigh strength.

超銳利の刃部、超精密密度の内外嵌め合い、超防銹、超硬度、耐磨耗、超耐衝擊性、超韌性、超強度の溶接



外 (outer)

A



内 (inner)

B

定制需注明:

以上系列规格的总长度均可依要求定制

以上只图示刨刀头部位置的内外径尺寸(漸刃外径尺寸,可依选择组合及配合要求精研磨至所需的尺寸公差, 超精密内外刀配合)

选好齿型(样本没有的齿型需批量才能定制或来图来样咨询)

溯所需整套的详细的内、外规格、总长度及精研磨的公差要求.....

Remarks needed for customization:

1.The overall length of the series specifications above can be customized according to customers' requirement.

2.This only shows the ID & OD of the shaver blade cutting edge position (Cutting edge OD will be according to customers' preferential combination, match up the requirement to finish grind to required tolerance, with ultra-high precision cooperation of inner tubes and outer tubes)

3.Choose the tooth profile. (For tooth profile that is not in our catalog, we can customize according to customers' drawings or samples but only with batch qty)

4. Need to know the detailed specifications of outer tube and inner tube, such as diameter, total length and tolerance requirement of fine grinding.

★依圖依樣尺寸/公差/要求復合成型加工，可生產極為複雜、精密的柄部形狀。Compound contour machining according to the sizes/tolerances/requirements of drawings and samples, we can produce extreme complex and accurate holder profile.

図面、サンプル、寸法または公差の要求により復合成型加工を行い、極めて複雑、精密な柄部の形状を生産できる。