

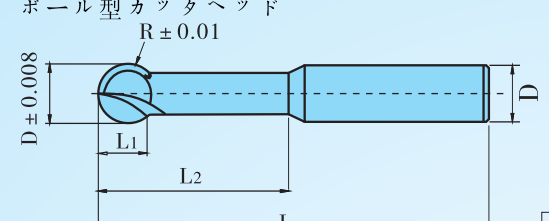
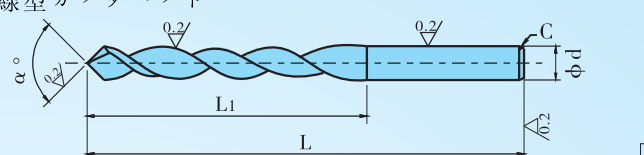
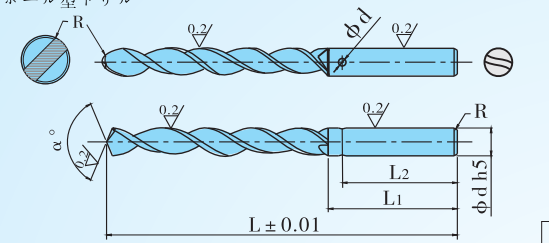
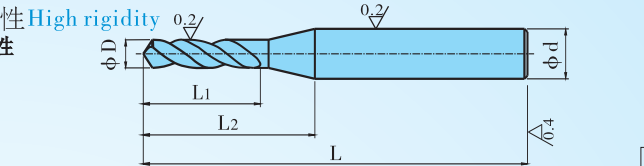
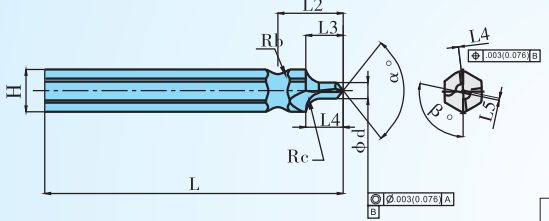
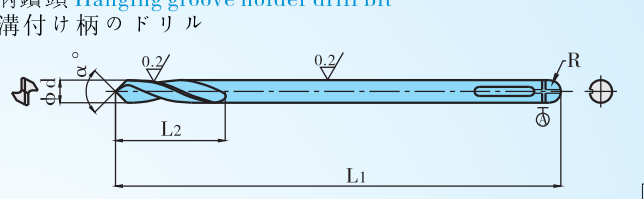
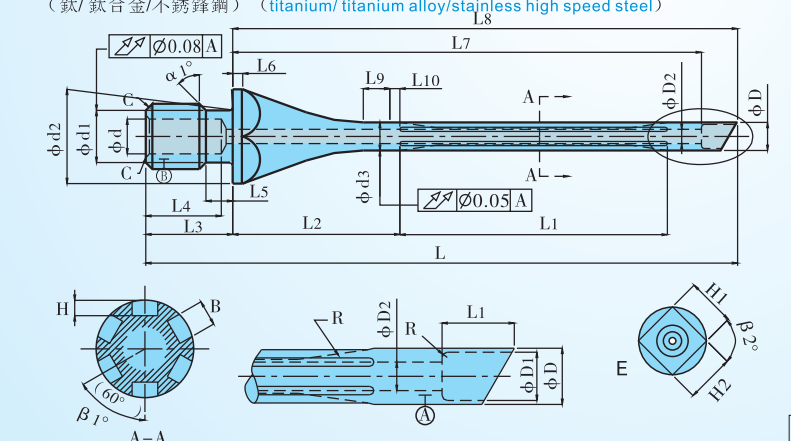
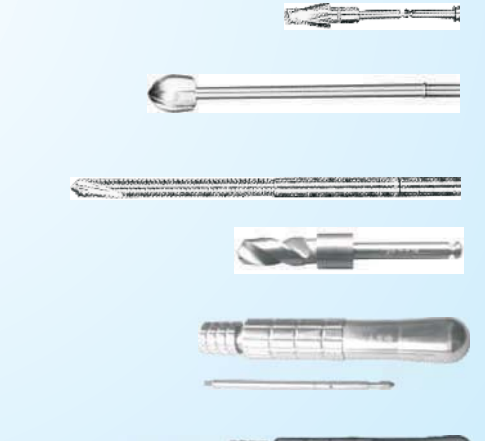
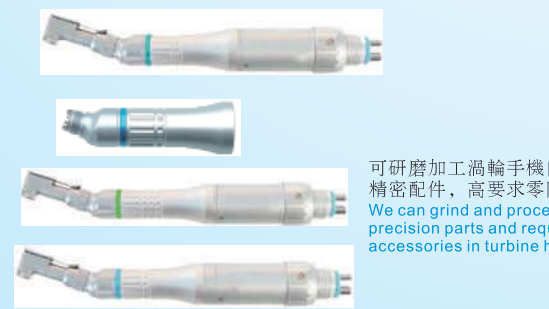

醫用工具及配件系列 (鑽針、骨鑽、骨科工具系列)

Medical tools and parts series (Drill points, Orthopedic drills, Orthopedic tools series)

医療器具及び部品シリーズ (ドリルピン、骨ドリル、整形外科工具)

(超防銹型(AA)&超高耐磨型(A))
(High anti-rust type AA)
& super wear-resistant type A)
(超防銹型(AA)&超高耐磨型(A))

<p>圓型球頭 Circular ball nose ボール型カッタヘッド</p>  <p>A</p>	<p>拋物頭 Parabola head 拋物線型カッタヘッド</p>  <p>B</p>
<p>球鑽 Ball nose Drill bit ボール型ドリル</p>  <p>C</p>	<p>高剛性 High rigidity 高剛性</p>  <p>D</p>
 <p>F</p>	<p>掛槽柄鑽頭 Hanging groove holder drill bit 掛け溝付け柄のドリル</p>  <p>E</p>
<p>小型細長孔特殊刀具 Small-sized special tooling with thin and long hole (鈦/鈦合金/不銹鋼) (titanium/titanium alloy/stainless high speed steel)</p>  <p>H</p>	
 <p>可研磨加工渦輪手機內的高精密配件，高要求零附件 We can grind and process high precision parts and requiring accessories in turbine hand tool</p>	

★ 依圖依樣尺寸/公差/要求復合成型加工，可生產極為複雜、精密的柄部形狀。Compound contour machining according to the sizes/tolerances/requirements of drawings and samples, we can produce extreme complex and accurate holder profile.
圖面、サンプル、寸法または公差の要求により復合成型加工を行い、極めて複雑、精密な柄部の形状を生産できる。