

★.依圖依樣尺寸/公差/要求復合成型加工可生產極為複雜\精密的柄部結構形狀。

Compound contour machining according to the sizes/ tolerances/ requirements of drawings and samples; we can produce extremely complex and accurate holder structure profile.

図面、サンプル、寸法または公差の要求により復合成型加工を行い、極めて複雑、精密な柄部の形状を生産できる。

★、刃口結構可以任意的排屑方式(如,上排屑、下排屑、左旋右切、右旋左切、左旋左切、右旋右切等等。高螺旋刃,低螺旋刃,帶導柱不帶導柱等等,結構形狀之方式。

edge structure can be applicable to any chip removing methods(such as, upper chip removal, lower chip removal, left handed right cutting, right handed left cutting, left handed left cutting, and right handed right cutting, etc. High helical edge, low helical edge, with guide pillar or without guide pillar, etc, different structures and shapes.

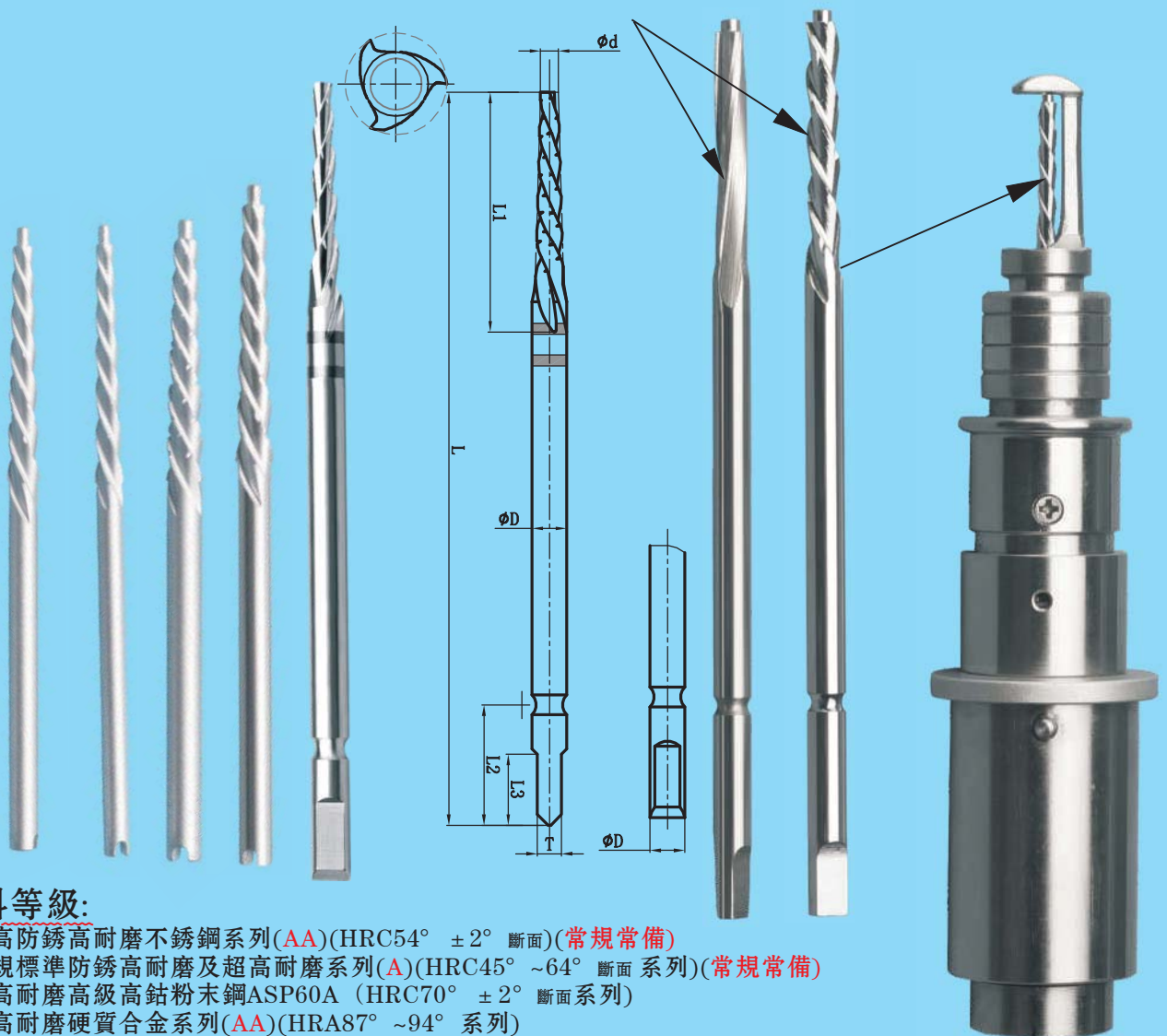

材料等級:

- ① 超高防銹高耐磨不銹鋼系列(AA)(HRC54° ± 2° 斷面)(常規常備)
- ② 常規標準防銹高耐磨及超高耐磨系列(A)(HRC45° ~64° 斷面系列)(常規常備)
- ③ 超高耐磨高級高鈷粉末鋼ASP60A (HRC70° ± 2° 斷面系列)
- ④ 超高耐磨硬質合金系列(AA)(HRA87° ~94° 系列)

Material grade:

- ① ultra-high anti-rust high wear-resistant stainless steel series (AA)(HRC54° ± 2° Section)(regular stock)
- ② general standard anti-rust, high wear-resistant and ultra-high wear-resistant series (A)
(HRC45° ~64° Section Series)(regular stock)
- ③ Super high wear resistant high-grade high cobalt powder steel ASP60A(HRC70° ± 2° section series)
- ④ ultra-high wear-resistant hard alloy series(AA)(HRA87° ~94° series)

★可超硬、超精研磨。任意的柄部類型。芯厚。容屑槽寬度。刃背方式。鑽尖方式。內冷卻孔方式。刃部結構。刃口角度。刃口鋒利程度之要求。及高可至 ±0.003mm (3μm) 的尺寸公差要求。We can produce with super hard and super finish grinding and satisfy your requirement of any type of shank, web thickness, width of chip flute, land, drill tip, inner cooling hole, structure of cutting edge, angle of cutting edge, degree of sharpness of cutting edge, and the dimension tolerance can be up to ±0.003mm (3μm)