

醫用工具及配件系列(內冷卻孔鑽頭)
 Medical tools and parts series(Drill with internal cooling hole)
 醫療器具及び部品シリーズ (内冷却穴ドリルヘッド)

(超高防銹高耐磨 (AA) & 高精密特殊非標成型)
 (ultra-high anti-rust(AA)&high
 precision special nonstandard forming)
 超防銹高耐磨耗(AA)&高精密特殊非標準成型

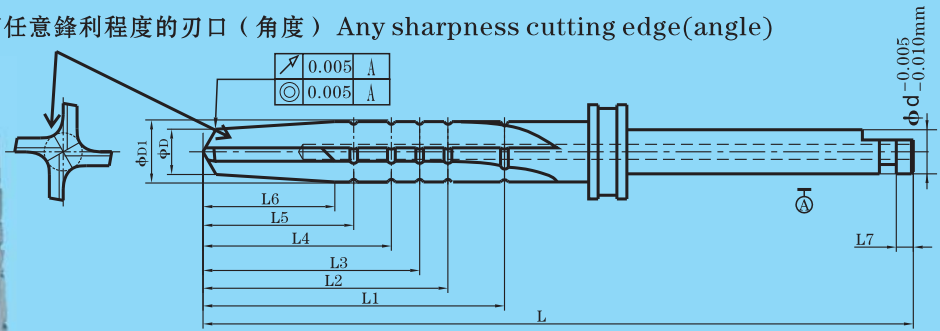

可任意鋒利程度的刃口 (角度) Any sharpness cutting edge (angle)



刃徑 φD Diameter	2.0	2.0	2.4	2.6	3.2	3.8	4.6
刃徑 φD1 Diameter	2.0	2.9	3.2	3.65	4.1	4.6	5.3
有效刃長 L1 Effective length of cutting edge 刃の長さ	16	16	16	16	16	16	16
柄徑 φd Shank Dia.	2.35	2.35	2.35	2.35	2.35	2.35	2.35
總長 L Overall length 總長さ	37.7	37.7	37.7	37.7	37.7	37.7	37.7
刃數 Z No. of flute	4	4	4	4	4	4	4

★、可以生产内冲水孔 (内冷却孔),也可以生产不要内冲水孔的。Either with inner punching hole (inner cooling hole) or without inner punching hole.

※ 必要可帶穿透&不穿透, 不同等級加工的中空、空芯內孔加工。
 With or without penetration, hollow & hollow core inner hole process with different grades.
 必要に応じて、貫通付き&貫通なし、各レベル加工での中空、中空内穴加工。

★可超硬、超精研磨, 任意的柄部類型, 芯厚, 容屑槽寬度, 刃背方式, 鑽尖方式, 內冷卻孔方式, 刃部結構, 刃口角度, 刃口鋒利程度之要求, 及高可至 ±0.003mm (3μm) 的尺寸公差要求 We can produce with super hard and super finish grinding and satisfy your requirement of any type of shank, web thickness, width of chip flute, land, drill tip, inner cooling hole, structure of cutting edge, angle of cutting edge, degree of sharpness of cutting edge, and the dimension tolerance can be up to ±0.003mm (3μm)